

# SELLERS

SPECIFICATION SHEET NO.

## 8500

MARCH 1, 2004

### BLOWOFF SEPARATOR WITH AFTERCOOLER

---

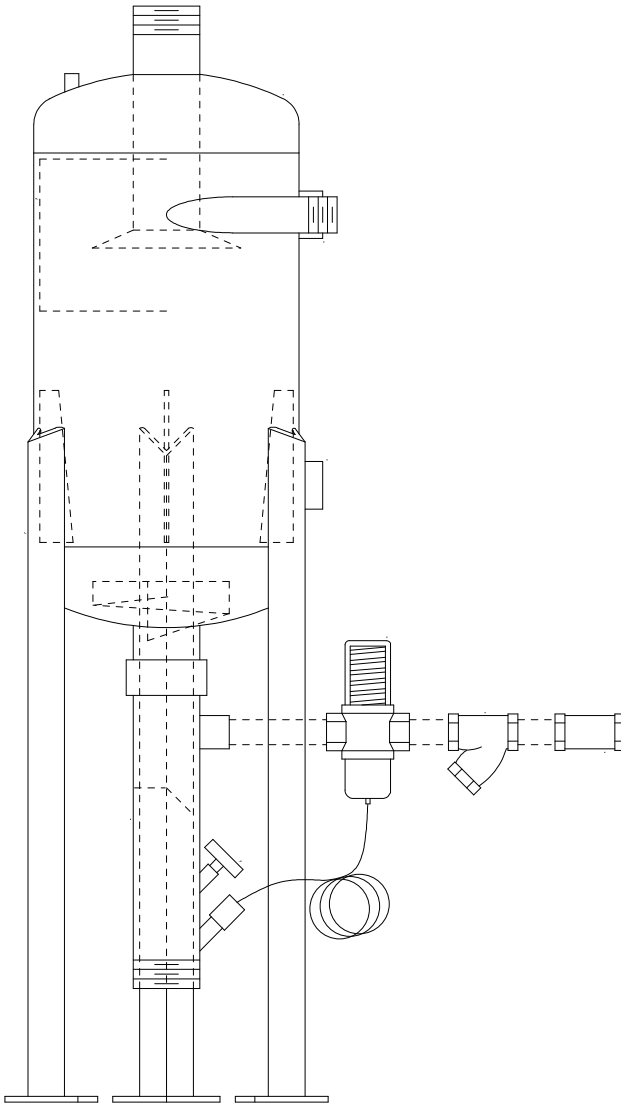

#### STANDARD FEATURES:

- ASME SECTION VIII TANK
- CYCLONIC SEPARATION OF STEAM & CONDENSATE
- STAINLESS STEEL STRIKING PLATE FOR LONGEVITY

#### EQUIPMENT:

- ANGLE IRON LEGS WITH FLOOR PADS
- AFTERCOOLER DRAIN FITTING
- SELF CONTAINED TEMPERATURE REGULATING VALVE
- BIMETAL THERMOMETER
- COOLING WATER STRAINER AND CHECK VALVE
- HARD ENAMEL FINISH



PO BOX 48 • DANVILLE, KENTUCKY 40423-0048

PHONE (859) 236-3181

[www.sellersengineering.com](http://www.sellersengineering.com)

# BLOWOFF SEPARATOR SELECTION

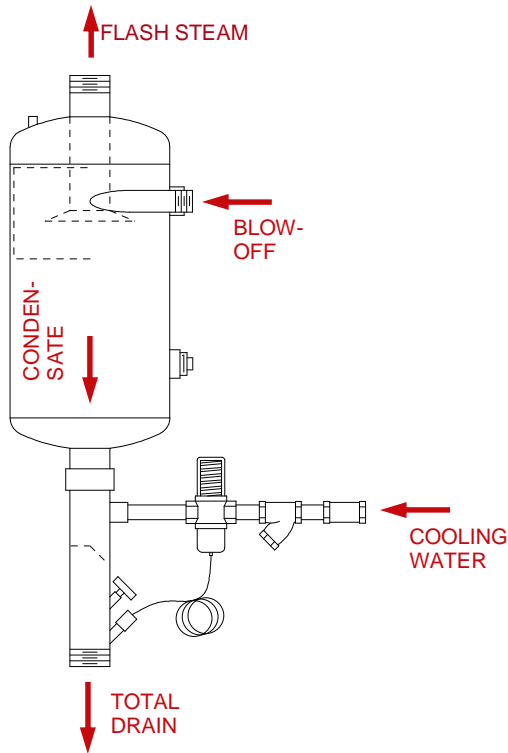

## SELECTION EXAMPLE

BOILER HP 200  
 OPERATING PRESSURE (PSI) 115  
 BLOWOFF VALVE SIZE 2"

1. ENTER CHART AT THE 200-800 HP SECTION
2. FIND OPERATING RANGE (115 PSI IS BETWEEN 100 AND 150 PSI)
3. SELECT MODEL BDS-20C WITH 2" INLET, 6" VENT & DRAIN AND 2" COOLING WATER VALVE

## OPERATING CHARACTERISTICS ARE:

BLOWOFF FLOW 79,721 PPH  
 CONDENSATE FLOW 137.12 GPM  
 COOLING WATER FLOW 141.09 GPM  
 TOTAL DRAIN FLOW 278.21 GPM  
 FLASH STEAM 11,162 PPH

BOILER HORSE-POWER	OPERATING PRESSURE	TANK SIZE	INLET	DRAIN	VENT	COOLING WATER INLET	MODEL	BLOWOFF FLOW (PPH)	CONDENSATE FLOW (GPM)	COOLING WATER FLOW (GPM)	TOTAL DRAIN FLOW (GPM)	FLASH STEAM (PPH)
10-30	0-50	14 X 20	1	2	2	1/2	BDS-10A	6444	12.17	12.52	24.69	360
	50-100	14 X 20	1	3	3	1/2	BDS-10B	11844	21.18	21.80	42.98	1252
	100-150	14 X 34	1	3	4	1/2	BDS-10C	15394	26.48	27.25	53.72	2155
	150-200	14 X 34	1	3	4	3/4	BDS-10D	19690	32.84	33.80	66.64	3268
	200-250	14 X 34	1	4	4	1	BDS-10E	21838	35.25	36.27	71.52	4214
	250-300	14 X 56	1	4	6	1-1/4	BDS-10F	25060	39.70	40.85	80.54	5212
40-70	0-50	14 X 20	1-1/4	3	3	1/2	BDS-12A	13472	25.44	26.17	51.61	754
	50-100	14 X 34	1-1/4	3	4	3/4	BDS-12B	22284	39.67	40.82	80.49	2448
	100-150	14 X 34	1-1/4	4	4	1	BDS-12C	30792	52.96	54.50	107.46	4310
	150-200	14 X 34	1-1/4	4	6	1-1/4	BDS-12D	37848	63.13	64.96	128.09	6282
	200-250	14 X 56	1-1/4	4	6	1-1/2	BDS-12E	42339	68.34	70.32	138.65	8171
	250-300	14 X 56	1-1/4	4	6	1-1/2	BDS-12E	48754	77.23	79.47	156.70	10140
80-175	0-50	14 X 34	1-1/2	3	3	3/4	BDS-15A	19437	36.70	37.76	74.46	1088
	50-100	14 X 34	1-1/2	4	4	1	BDS-15B	33573	60.03	61.77	121.80	3558
	100-150	14 X 34	1-1/2	4	6	1-1/4	BDS-15C	44625	76.88	79.11	155.99	6184
	150-200	14 X 56	1-1/2	4	6	1-1/2	BDS-15D	53893	89.89	92.50	182.39	8946
	200-250	14 X 56	1-1/2	4	6	2	BDS-15E	60962	98.39	101.25	199.64	11765
	250-300	14 X 56	1-1/2	6	6	2	BDS-15F	69796	110.56	113.76	224.32	14517
200-800	0-50	14 X 34	2	4	4	1-1/4	BDS-20A	37454	70.69	72.74	143.43	2108
	50-100	14 X 34	2	4	6	2	BDS-20B	60,536	108.24	111.38	219.62	6416
	100-150	14 X 56	2	6	6	2	BDS-20C	79721	137.12	141.09	278.21	11162
	150-200	14 X 56	2	6	6	2	BDS-20C	94496	157.62	162.19	319.81	15686
	200-250	14 X 56	2	6	6	2-1/2	BDS-20D	109261	176.35	181.46	357.81	21087
	250-300	14 X 56	2	6	6	2-1/2	BDS-20D	122550	194.12	199.75	393.87	25490

# BLOWOFF SEPARATOR DIMENSIONS

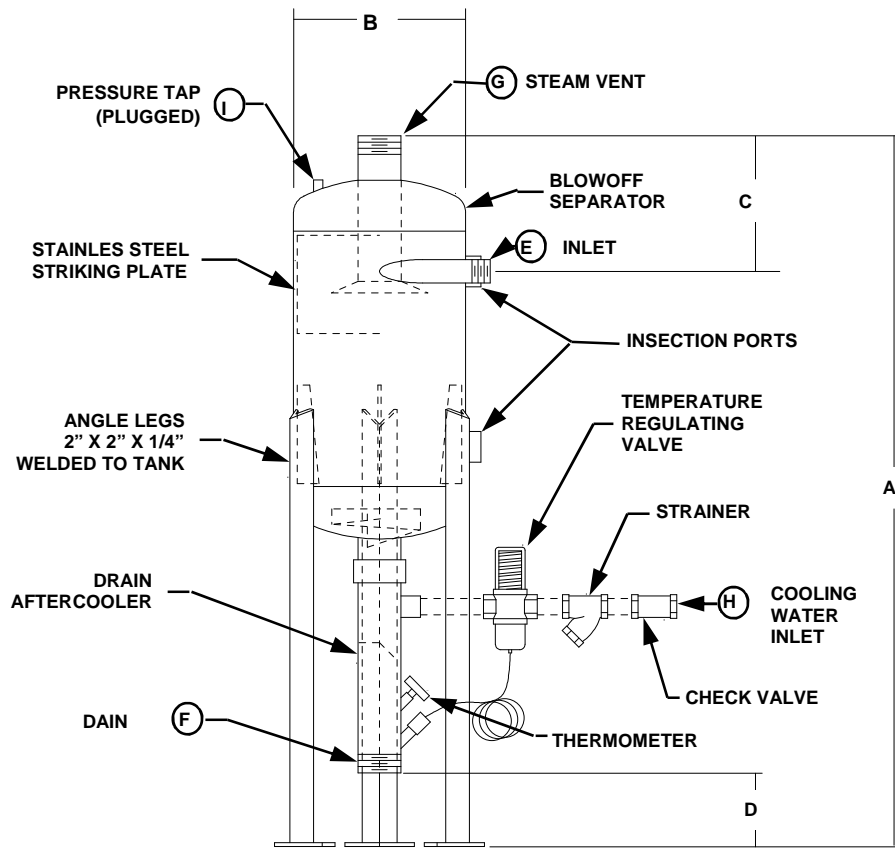

MODEL	HEIGHT	DIAMETER			INLET	DRAIN	VENT	CWI	
	A	B	C	D	E	F	G	H	I
BDS-10A	42	14	11	2	1	2	2	1/2	1/4"
BDS-10B	45	14	11	4	1	3	3	1/2	1/4"
BDS-10C	58	14	11	4	1	3	4	1/2	1/4"
BDS-10D	58	14	11	4	1	3	4	3/4	1/4"
BDS-10E	59	14	11	5	1	4	4	1	1/4"
BDS-10F	81	14	11	5	1	4	6	1-1/4	1/4"
BDS-12A	44	14	11	4	1-1/4	3	3	1/2	1/4"
BDS-12B	58	14	11	5	1-1/4	3	4	3/4	1/4"
BDS-12C	59	14	11	5	1-1/4	4	4	1	1/4"
BDS-12D	59	14	11	5	1-1/4	4	6	1-1/4	1/4"
BDS-12E	81	14	11	5	1-1/4	4	6	1-1/2	1/4"
BDS-15A	58	14	11	4	1-1/2	3	3	3/4	1/4"
BDS-15B	59	14	11	5	1-1/2	4	4	1	1/4"
BDS-15C	59	14	11	5	1-1/2	4	6	1-1/4	1/4"
BDS-15D	81	14	11	5	1-1/2	4	6	1-1/2	1/4"
BDS-15E	81	14	11	5	1-1/2	4	6	2	1/4"
BDS-15F	90	14	11	14	1-1/2	6	6	2	1/4"
BDS-20A	59	14	11	5	2	4	4	1-1/4	1/4"
BDS-20B	59	14	11	5	2	4	6	2	1/4"
BDS-20C	90	14	11	14	2	6	6	2	1/4"
BDS-20D	90	14	11	14	2	6	6	2-1/2	1/4"

# BLOWOFF SEPARATOR SAMPLE SPECIFICATIONS

Furnish and install \_\_\_ Boiler Blowoff Separator(s) Model No. BDS-\_\_\_\_" with \_\_\_" Inlet, \_\_\_" Vent, \_\_\_" Drain and \_\_\_" thick striking plate.

The separator vessel shall be fabricated of welded carbon steel, designed and "UM" Stamped to the ASME Code for 250 PSIG at 450° F and National Board "U" Stamp as Required for Location of installation. (Flanged units shall be limited to pressure rating of the flanges and stamped accordingly.)

Connections shall be threaded (Weld Bevel, or Flanged) and shall include a tangential inlet, steam vent, and drain.

Separator shall incorporate a stainless steel striking plate at the inlet and a stainless steel spiral baffle at the drain. The exterior finished with hard enamel.

## ACCESSORIES

Furnish and install the Separator with three angle legs for floor mounting or brackets for wall mounting.

Furnish and install an automatic aftercooler drain fitting with \_\_\_" temperature regulating valve, cast iron strainer, bronze ball cone check valve and bi-metal thermometer. Furnish a pressure reducing valve if cooling water supply pressure exceeds 60 PSIG.



**Sellers ENGINEERING COMPANY**

PO BOX 48 • DANVILLE, KENTUCKY 40423-0048

PHONE (859) 236-3181

[www.sellersengineering.com](http://www.sellersengineering.com)