

SELLERS

SPECIFICATION SHEET NO.

7000

January 1, 2006

MODEL BT WATER HEATER

GENERAL DESCRIPTION

The Sellers Model BT water Heater is a rugged commercial-industrial gas fired assembly. It combines hi-storage and hi-recovery in a single complete unit. Immersion firing provides high efficiency with minimum maintenance. The heaters are approved as a unit by Underwriters Laboratories and factory fire tested before shipment.

SHELL SPECIFICATIONS

All Sellers Water Heaters are built to conform with Section IV of the ASME code and stamped with the "H" cloverleaf. Licensed inspectors check construction and witness final pressure testing. An ASME Inspection Data Report is furnished. The pressure vessels are available for standard maximum design pressures of 100, 125 or 150 psi.

Handhole openings are provided at front, rear and bottom of the shells for inspection and cleaning. The pressure vessel is warranted for 10 years against leakage. See warranty for details.

SCALE CRACKING

The long, small diameter firing tubes in Sellers Immersion Water Heaters expand and contract sufficiently on intermittent firing to break loose hard scale that might form on the tubes. It drops to the cool bottom in small pieces which can be washed out through the clean-out openings. With immersion firing, harder water can be heated. Tubes stay cleaner.

GENERAL FIRING DETAILS

All of the combustion air – both primary and secondary – is provided by a direct connect, motor driven blower with the housing and fan internally mounted in the burner assembly. The combustion chamber is pressurized by the secondary air which is controlled by means of an outside adjustable valve.

The primary air is metered to the approximate volume required by a fixed air jet in the built-in air gas mixer. An adjustable shutter is provided at the inlet to the blower to allow minor adjustments as required on a particular installation.

The burner, except for the electrical parts, the gas pressure regulator and the blower impeller, are warranted for 5 years.

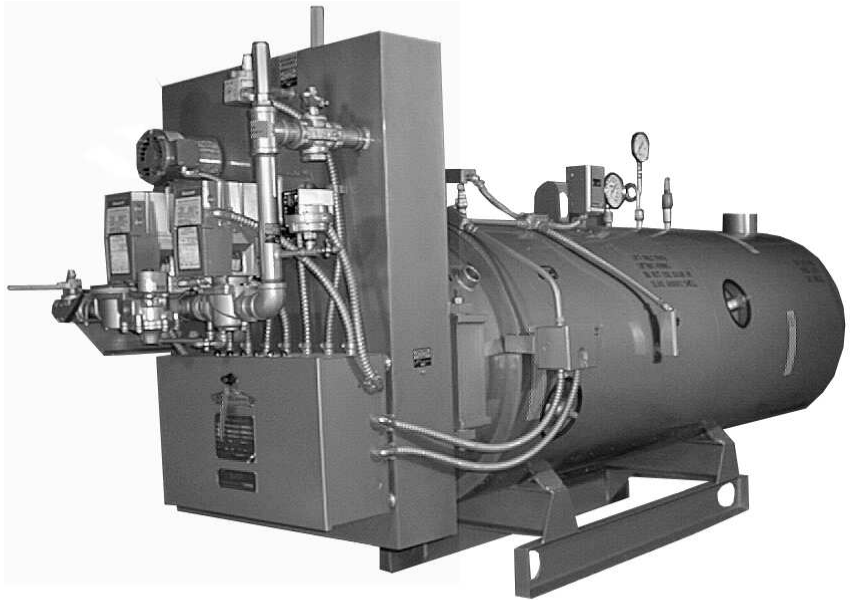

EMISSIONS

Optional low NOx emission package will allow the unit to operate at less than 30 ppm of NOx to meet low emission demands. This is achieved without flue gas recirculation and for very little additional cost. The standard unit will operate at less than 50 ppm Nox.

COMBUSTION SAFEGUARD

An electronic flame safeguard is provided with each burner. The standard flame safeguard provides automatic sequencing and checking of each step of the burner operation.

OPERATING SEQUENCE

On a call for heat by the water heater operating temperature control, the limits are checked for safety and the blower motor starts. The air supply is proved and the burner is pre-purged for 30 seconds. After pre-purge, the runner pilot gas valve opens and the runner pilot is spark ignited. Spark is continuously maintained through the combustion cycle. After the runner pilots have made a traverse below all burner nozzles and have been proved by the flame rod within 10 seconds, the main gas valve opens. When the call for heat is satisfied, a 15 second post purge of the heater completes the cycle.

Standard safety controls monitoring the combustion cycle include low water cutoff, high limit temperature control and air proving switch. The electronic combustion safeguard provides 100% safety shutdown within 3 seconds of flame failure.

SELLERS ENGINEERING CO., MANUFACTURING BOILERS AND WATER HEATERS SINCE 1931.



WATER HEATER STORAGE AND RECOVERY CAPACITIES

SEA LEVEL TO 3000 FEET ALTITUDE

CATALOG NUMBER	HOURLY BTU INPUT	HOURLY RECOVERY CAPACITY – GPH / F.			STORAGE CAPACITY (U.S. GAL)	SHIPPING WEIGHTS (POUNDS)		
		40-120°	40-140°	40-180°		100#	125#	150#
BT-8-250	800,000	994	790	558	235	3,380	3,380	3,380
BT-8-360					345	3,640	3,870	4,150
BT-8-650					625	4,735	4,890	5,170
BT-12-250	1,200,000	1,491	1,186	836	230	3,780	3,800	3,800
BT-12-360					340	4,100	4,100	4,300
BT-12-650					615	5,000	5,150	5,440
BT-16-1000					975	5,650	5,940	6,370
BT-16-250	1,600,000	1,988	1,581	1,115	225	3,900	3,900	3,940
BT-16-360					330	4,220	4,220	4,440
BT-16-650					610	5,140	5,290	5,580
BT-16-1000					965	5,700	5,950	6,350
BT-16-1500					1,490	7,100	7,500	8,300
BT-20-250	2,000,000	2,485	1,976	1,394	215	4,050	4,100	4,100
BT-20-360					325	4,350	4,350	4,400
BT-20-650					600	5,200	5,350	5,640
BT-20-1000					960	5,850	6,130	6,560
BT-20-2100					2,080	8,950	9,420	9,850
BT-20-2800					2,790	12,000	13,100	14,100
BT-24-360	2,400,000	2,982	2,371	1,673	320	5,100	5,150	5,350
BT-24-650					595	6,200	6,350	6,620
BT-24-1000					955	6,800	7,080	7,510
BT-24-1500					1,470	8,100	8,500	9,100
BT-32-360	3,200,000	3,976	3,161	2,230	305	5,250	5,250	5,460
BT-32-650					585	6,200	6,350	6,630
BT-32-1000					940	6,800	7,090	7,520
BT-32-1500					1,455	8,200	8,600	9,200
BT-40-650	4,000,000	4,970	3,952	2,788	570	6,600	6,750	7,030
BT-40-1000					930	7,100	7,390	7,820
BT-40-1500					1,440	8,730	9,130	9,730
BT-40-2100					2,040	11,530	12,000	13,430
BT-40-2800					2,750	12,640	13,200	14,500

Larger Sizes Continued on the following page.

WATER HEATER STORAGE AND RECOVERY CAPACITIES

SEA LEVEL TO 3000 FEET ALTITUDE

CATALOG NUMBER	HOURLY BTU INPUT	HOURLY RECOVERY CAPACITY – GPH / F.			STORAGE CAPACITY (U.S. GAL)	SHIPPING WEIGHTS (POUNDS)		
		40-120°	40-140°	40-180°		100#	125#	150#
BT-50-650	5,000,000	6,212	4,940	3,485	550	6,750	6,900	7,180
BT-50-1000					910	7,250	7,540	7,970
BT-50-1500					1,420	8,880	9,270	9,870
BT-60-1500	6,000,000	7,455	5,928	4,182	1,405	10,900	11,360	11,960
BT-60-2100					2,010	12,600	13,150	13,620
BT-60-2800					2,720	13,940	15,030	16,120
BT-70-1000	7,000,000	8,697	6,916	4,879	870	8,460	8,750	9,040
BT-80-1500	8,000,000	9,940	7,904	5,576	1,365	9,400	9,790	10,180
BT-80-2100	8,000,000	9,940	7,904	5,576	1,970	12,800	13,270	14,700
BT-80-2800	8,000,000	9,940	7,904	5,576	2,675	13,700	14,790	15,780
BT-90-1000	9,000,000	11,182	8,892	6,273	840	8,900	9,190	9,620
BT-100-1500	10,000,000	12,425	9,880	6,970	1,330	11,000	11,390	11,990
BT-100-2100	10,000,000	12,425	9,880	6,970	1,930	13,500	13,970	15,400
BT-100-2800	10,000,000	12,425	9,880	6,970	2,640	14,600	15,690	16,780
BT-110-1000	11,000,000	13,667	10,867	7,667	810	9,300	9,590	10,020
BT-120-1500	12,000,000	14,910	11,855	8,364	1,290	13,800	14,190	14,790
BT-120-2100	12,000,000	14,910	11,855	8,364	1,895	15,100	15,600	17,000
BT-120-2800	12,000,000	14,910	11,855	8,364	2,600	15,700	16,750	18,100
BT-140-1500	14,000,000	17,395	13,831	9,758	1,255	14,200	14,590	15,190
BT-140-2100	14,000,000	17,395	13,831	9,758	1,855	15,900	16,400	17,850
BT-140-2800	14,000,000	17,395	13,831	9,758	2,560	16,450	17,550	18,900
BT-160-2100	16,000,000	19,880	15,807	11,152	1,815	17,100	17,600	19,000
BT-160-2800	16,000,000	19,880	15,807	11,152	2,525	17,700	18,750	20,000
BT-200-2800	20,000,000	24,849	19,759	13,940	2,445	18,500	19,550	20,800

Installation Requirements

ELECTRICAL REQUIREMENTS

Water Heaters are pre-wired (105° C color coded wire) to numbered terminal strips. The wiring diagram is provided in the control panel and with the owners manual. Panels include a control transformer to provide 5 Amp., 120 Volt service. Boilers are wired for jobsite supply power characteristics.

AIR REQUIREMENTS

Provide 1/2 square foot of free air inlet area per 1,000,000 BTU input to the burner. Cross ventilation is preferred in lieu of a single opening.

STACK REQUIREMENTS

Design stack to provide .02" to .04" water column draft at flue outlet. Smooth transitions and bends are required. Generally full sized rectangular or equivalent round stacks should be used. Maximum stack weight on water heater should not exceed 1000 pounds.

GAS REQUIREMENTS

Main and pilot gas pressure regulators are supplied with each boiler. Refer to the chart below for gas pressure requirements. Pressures shown are with the unit running. For pressure above 10 PSI, install a second regulator to reduce the pressure to the standard range.

Standard Gas Pressure Requirements (Natural Gas at 0-3000 ft. Elevation)

Water Heater Model Prefix Number	Pressure required at gas train inlet		
	Min. (3)	Std Range	Max.
BT-8	6" w.c.	8" to 1 PSI	10 PSI
BT-12 through BT-32	7" w.c.	12" to 1 PSI	10 PSI
BT-40 through BT-50	10" w.c.	14" to 1 PSI	10 PSI
BT-60 through BT-380	14" w.c.	18" to 1 PSI	10 PSI
BT-90 through BT-110	14" w.c.	2 to 10 PSI	10 PSI
BT-120 through BT-160	14" w.c.	1.5 TO 10 PSI	10 PSI
BT-200	1 PSI	2 TO 10 PSI	10 PSI

(3) Special gas trains required at additional cost. Consult the Factory.

STANDARD EQUIPMENT FURNISHED

Pressure Vessel: ASME stamped with "H" cloverleaf.

Copper Clad Tubes: Seamless .028" copper drawn tightly over steel.

Manholes: Standard on shells over 60" diameter.

Handholes: Five (5) furnished, 3-1/2" x 4-1/2".

Energy X-tractors: High temperature stainless steel to provide high efficiency. Installed in each tube.

Base: Heavy duty structural steel skid.

Insulation: 2" fiberglass with double painted steel jacket with precast hardtop walkway.

Epoxy Lining: Epoxy phenolic lining applied to san blasted surface and baked at high temperature.

Magnesium Anodes: Two (2) 1-5/16" x82 or longer.

Relief Door: Gravity operated for rear access and safety.

Burner Assembly: Hinged to shell including:

- ◆ Blower assembly with drip proof motor.
- ◆ Air gas mixer.
- ◆ Individual burner nozzles.
- ◆ Air proving switch.
- ◆ Ignition transformer, spark and flame rods.
- ◆ Gas control trains with dual main shutoff cocks, pilot and main gas pressure regulators, gas volume adjustment and other components as follows:

	BT-8 BT-12	BT-16 BT-24	BT-32 BT-40	BT-50	BT-60 BT-120	BT-140 BT-200
Solenoid gas valve	2	-	-	-	-	-
Motorized gas valve	-	1	1	2	2	2
Proof of closure	-	1	1	1	1	1
Pilot solenoid valves	1	1	1	1	2	2
Gas pressure switches	-	-	2	2	2	2
Vent valve	-	-	-	-	-	1

Operating Temperature Control

High Limit Temperature Control: Manual reset.

UL Labeled: Packaged water heaters.

Lifting lugs: One or more provided on each boiler.

Low Water Cutoffs: Probe type with manual reset.

Pressure Gauge: 4-1/2" dial type mounted on pigtail.

Temperature Gauge: 5" dial type.

Temperature and Pressure Relief Valve(s): ASME rated for full boiler nozzle output at design pressure rating.

Flame observation ports: Two or more provided in combustion chamber to view burners.

Control Panel: With motor starter, control transformer with primary and secondary fuses, flame safeguard control (Honeywell RM7840), six (6) indicating lights. Optional flame safeguard controls available are Honeywell RM7800 and Fireye E110.

Factory fire test report.

Five year limited burner warranty.

Ten year warranty on pressure vessel.

Finished with heavy jade green machinery enamel.

Initial start-up and operator's instruction provided by a company representative.

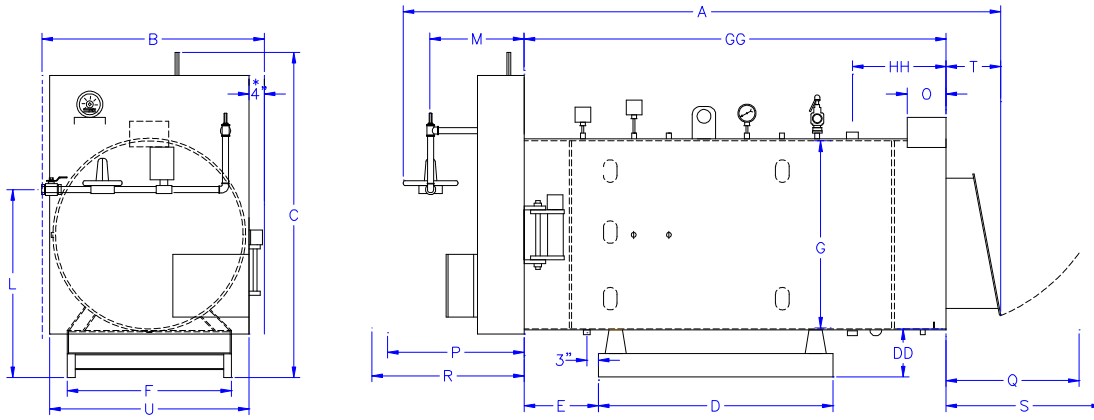

WATER HEATER DIMENSIONS

MODEL NUMBER:		BT-8-250	BT-8-360	BT-8-650	BT-12-250	BT-12-360	BT-12-650	BT-16-250	BT-16-360	BT-16-650	BT-20-250	BT-20-360	BT-20-650	BT-24-360	BT-24-650	
OVERALL DIMENSIONS:																
LENGTH	A	142	142	146	147	147	151	147	147	151	147	147	151	149	153	
WIDTH	B	41	46	59	41	46	59	41	46	59	41	46	59	46	59	
HEIGHT	C	66	69	79	66	69	79	66	74	79	66	74	83	74	83	
BASE:																
LENGTH	D	60	60	60	60	60	60	60	60	60	60	60	60	60	60	60
HEIGHT	DD	12	12	12	12	12	12	12	12	12	12	12	12	12	12	12
LOCATION	E	19	19	19	19	19	19	19	19	19	19	19	19	19	19	19
WIDTH	F	24	30	42	24	30	42	24	30	42	24	30	42	30	42	
SHELL:																
LENGTH	GG	108	108	108	108	108	108	108	108	108	108	108	108	108	108	108
DIAMETER INSIDE	G	30	36	48	30	36	48	30	36	48	30	36	48	36	48	
OPENINGS:																
HOT OR COLD IPS	H	2	2	2	2	2	2	2	2	2	2	2	2	2	2	2
HOT WATER OUTLET LOCATION	HH	24	24	24	24	24	24	24	24	24	24	24	24	24	24	24
GAS CONNECTION:																
VERTICAL	L	36	39	48	36	39	48	36	39	48	36	39	48	39	48	
HORIZONTAL	M	20	20	20	22	22	22	22	22	22	22	22	22	22	24	24
FLUE CONNECTION:	O	6	6	6	8	8	8	10	10	10	10	10	10	10	10 x 10	10 x 10
INSTALLATION CLEARANCES:																
COMBUSTION ASSEMBLY SWING	P	42	47	60	46	50	63	46	50	63	46	50	63	51	64	
RELIEF DOOR SWING (NOTE 7)	Q	17	19	34	17	19	34	17	19	34	17	19	34	19	34	
TUBE REMOVAL FRONT (NOTE 8)	R	73	73	73	73	73	73	73	73	73	73	73	73	73	73	73
TUBE REMOVAL REAR (NOTE 8)	S	71	71	71	71	71	71	71	71	71	71	71	71	71	71	71
RELIEF DOOR ASSEMBLY	T	10	10	14	10	10	14	10	10	14	10	10	14	10	14	14
MANIFOLD WIDTH	U	35	39	51	35	39	51	35	40	51	35	40	51	40	51	51
BLOWER HP:		1	1	1	1-1/2	1-1/2	1-1/2	1-1/2	1-1/2	1-1/2	2	2	2	3	3	3

See Notes on Last Page.

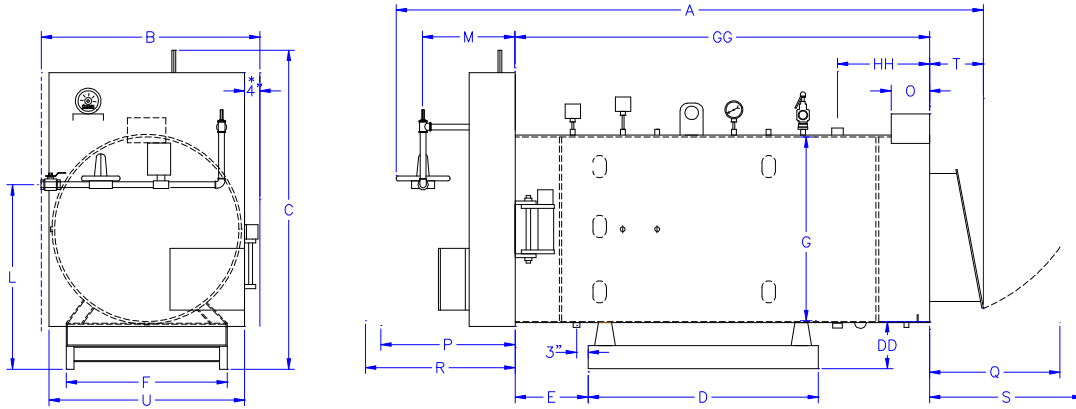

WATER HEATER DIMENSIONS

MODEL NUMBER: OVERALL DIMENSIONS:		BT-32-360	BT-32-650	BT-40-650	BT-50-650	BT-70-1000†	BT-90-1000†	BT-100-1500†	BT-110-1000†	BT-120-1500†	BT-140-1500†	BT-140-2100†	BT-160-2100†	BT-160-2800†	BT-200-2800†
LENGTH	A	153	157	163	163	179	181	205	185	209	209	210	210	212	212
WIDTH	B	46	59	59	59	72	77	78	90	90	90	91	96	96	96
HEIGHT	C	74	83	83	83	99	103	110	111	114	115	121	125	134	134
BASE:															
LENGTH	D	60	60	60	60	60	60	78	60	78	78	78	78	78	78
HEIGHT	DD	12	12	12	12	18	18	18	18	18	18	18	18	18	18
LOCATION	E	19	19	26	26	26	27	27	27	27	27	27	27	27	27
WIDTH	F	30	42	42	42	54	54	57	54	57	57	66	66	78	78
SHELL:															
LENGTH	GG	108	108	114	114	118	118	140	118	140	140	140	140	140	140
DIAMETER INSIDE	G	36	48	48	48	60	60	66	60	66	66	78	78	90	90
OPENINGS:															
HOT & COLD IPS	H	3	3	3	3	4 Flg.	4 Flg.	4 Flg.	4 Flg.	4 Flg.	4 Flg.	4 Flg.	4 Flg.	4 Flg.	4 Flg.
HOT WATER OUTLET LOCATION	HH	24	24	24	24	30	30	30	30	30	30	30	30	30	30
GAS CONNECTION:															
VERTICAL	L	39	48	48	48	48	48	48	48	48	48	48	48	48	48
HORIZONTAL	M	28	28	28	28	38	40	40	44	44	44	44	44	44	44
FLUE CONNECTION:	O	10x12	10x12	10x15	10x18	10x25	14x24	14x26	14x28	14x30	14x36	14x36	14x40	14x40	14x50
INSTALLATION CLEARANCES:															
COMBUSTION ASSEMBLY SWING	P	54	66	66	66	81	87	87	99	99	100	100	104	110	110
RELIEF DOOR SWING (NOTE 7)	Q	19	34	34	34	40	40	45	40	45	45	52	52	58	58
TUBE REMOVAL FRONT (NOTE 8)	R	73	73	66	66	66	66	88	66	88	88	88	88	88	88
TUBE REMOVAL REAR (NOTE 8)	S	71	71	72	72	68	68	90	68	90	90	90	90	90	90
RELIEF DOOR ASSEMBLY	T	10	14	14	14	15	15	17	15	17	17	18	18	20	20
MANIFOLD WIDTH	U	40	51	51	51	66	72	72	84	84	84	84	90	96	102
BLOWER HP:		3	3	5	5	7-1/2	10	10	15	15	15	15	15	15	20

See Notes on Last Page.

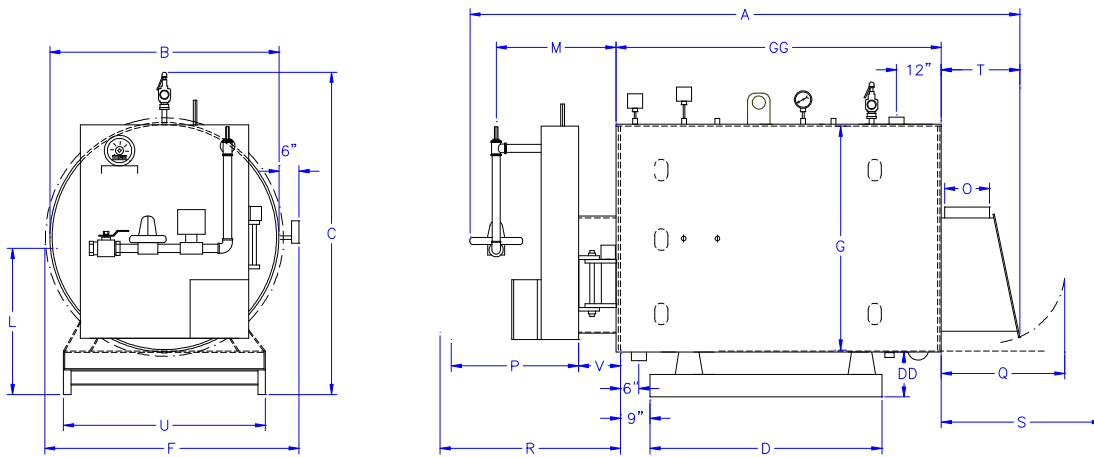

WATER HEATER DIMENSIONS

MODEL NUMBER:		BT-12-	BT-16-	BT-16-	BT-20-	BT-20-	BT-20-	BT-24-	BT-24-	BT-32-	BT-32-	BT-40-	BT-40-	BT-40-	BT-40-
OVERALL DIMENSIONS:		1000	1000	1500	1000	2100	2800	1000	1500	1000	1500	1000	1500	2100	2800
LENGTH	A	143	145	166	146	167	167	148	169	153	174	160	181	181	181
WIDTH	B	66	66	72	66	84	96	66	72	66	72	66	72	84	96
HEIGHT	C	82	82	91	82	104	116	86	91	86	91	88	91	104	116
BASE:															
LENGTH	D	60	60	78	60	78	78	60	78	60	78	60	78	78	78
HEIGHT	DD	12	12	12	12	12	12	12	12	12	12	12	12	12	12
WIDTH	F	54	54	57	54	66	78	54	57	54	57	54	57	66	78
SHELL:															
LENGTH	GG	87	87	108	87	108	108	87	108	87	108	87	108	108	108
DIAMETER INSIDE	G	60	60	66	60	78	90	60	66	60	66	60	66	78	90
OPENINGS:															
HOT OR COLD IPS	H	2	2	2	2	2	2	2	2	3	3	3	3	3	3
GAS CONNECTION:															
VERTICAL	L	36	36	36	36	36	36	39	39	39	39	42	42	42	42
HORIZONTAL	M	32	32	32	32	32	32	34	34	38	38	45	45	45	45
FLUE CONNECTION:	O	8	10	10	10	10	10	10x10	10x10	10x12	10x12	10x15	10x15	10x15	10x15
INSTALLATION CLEARANCES:															
COMBUSTION ASSEMBLY SWING	P	46	46	46	46	46	46	51	51	53	53	62	62	62	62
RELIEF DOOR SWING (NOTE 7)	Q	22	24	24	27	27	27	27	27	33	33	33	33	33	33
TUBE REMOVAL FRONT (NOTE 8)	R	83	83	105	83	105	105	83	105	83	105	83	105	105	105
TUBE REMOVAL REAR (NOTE 8)	S	83	83	105	83	105	105	83	105	83	105	83	105	105	105
RELIEF DOOR ASSEMBLY	T	17	19	19	20	20	20	20	20	21	21	21	21	21	21
MANIFOLD WIDTH	U	35	35	35	35	35	35	40	40	40	40	51	51	51	51
COMBUSTION CHAMBER	V	10	10	10	10	10	10	10	10	10	10	17	17	17	17
BLOWER HP:		1-1/2	1-1/2	1-1/2	2	2	2	3	3	3	3	5	5	5	5

See Notes on Last Page.

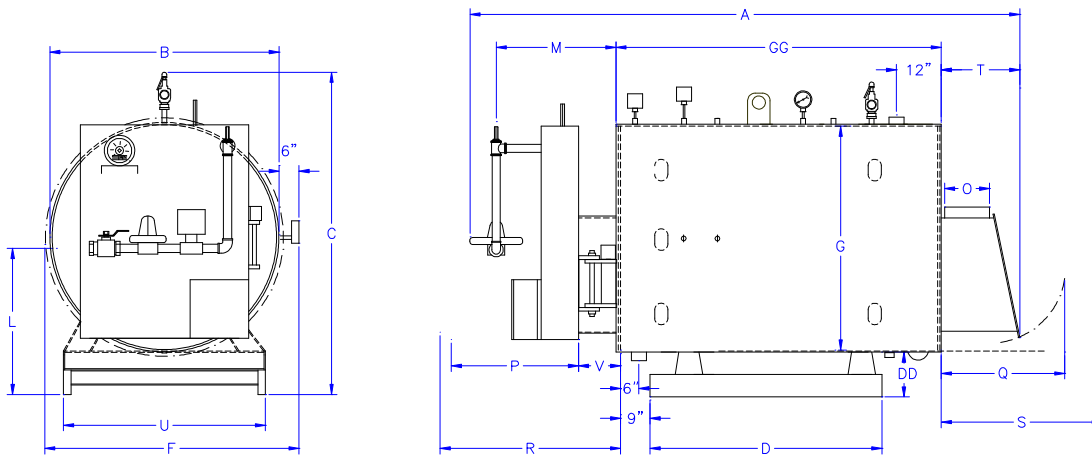

WATER HEATER DIMENSIONS

MODEL NUMBER:		BT-50-1000	BT-50-1500	BT-60-1500	BT-60-2100	BT-60-2800	BT-80-1500	BT-80-2100	BT-80-2800	BT-100-2100	BT-100-2800	BT-120-2100	BT-120-2800	BT-140-2800
OVERALL DIMENSIONS:														
LENGTH	A	161	182	187	187	187	194	194	194	202	202	206	206	207
WIDTH	B	66	72	72	84	96	72	84	96	84	96	84	96	96
HEIGHT	C	88	91	92	104	116	106	112	122	112	122	120	126	127
BASE:														
LENGTH	D	60	78	78	78	78	78	78	78	78	78	78	78	78
HEIGHT	DD	12	12	12	12	12	18	18	18	18	18	18	18	18
WIDTH	F	54	57	57	66	78	57	66	78	66	78	66	78	78
SHELL:														
LENGTH	GG	87	108	108	108	108	108	108	108	108	108	108	108	108
DIAMETER INSIDE	G	60	66	66	78	90	66	78	90	78	90	78	90	90
OPENINGS:														
HOT OR COLD IPS	H	3	3	3	3	3	4 Flg.	4 Flg.	4 Flg.	4 Flg.	4 Flg.	4 Flg.	4 Flg.	4 Flg.
GAS CONNECTION:														
VERTICAL	L	42	42	48	48	48	48	48	48	48	48	48	48	48
HORIZONTAL	M	45	45	49	49	49	55	55	55	57	57	61	61	61
FLUE CONNECTION:	O	10 x18	10x18	10 x22	10x22	10x22	10x28	10x28	10 x28	14x26	14x26	14x30	14x30	14 x36
INSTALLATION CLEARANCES:														
COMBUSTION ASSEMBLY SWING	P	62	62	68	68	68	81	81	81	87	87	99	99	99
RELIEF DOOR SWING (NOTE 7)	Q	36	36	36	36	36	42	42	42	52	52	52	52	55
TUBE REMOVAL FRONT (NOTE 8)	R	83	105	105	105	105	105	105	105	105	105	105	105	105
TUBE REMOVAL REAR (NOTE 8)	S	83	105	105	105	105	105	105	105	105	105	105	105	105
RELIEF DOOR ASSEMBLY	T	22	22	22	22	22	23	23	23	29	29	29	29	30
MANIFOLD WIDTH	U	51	51	55	55	55	66	66	66	72	72	84	84	84
COMBUSTION CHAMBER	V	17	17	17	17	17	17	17	17	17	17	17	17	17
BLOWER HP:		5	5	5	5	5	7-1/2	7-1/2	7-1/2	10	10	15	15	15

See Notes on Last Page.

NOTES

1. Dimensions are accurate for layout but are subject to change. Certified prints are available upon request.
 2. Lifting lugs are not shown on drawing. The manhole, when furnished, is not shown.
- * Dimension is 0" for model BT-160-2800 and BT-200-2800
† Hinged back plate furnished.

3. Outside diameter and dimensions are shown.
4. Tubes may be removed from the front or rear.
5. Horizontal gas train dimension will vary based on required gas train components and addition of Low NOx option. Gas train may extend beyond burner manifold dimension U.

OPTIONAL EXTERNAL CIRCULATING SYSTEM

INCREASED USABLE STORAGE

Provides increased usable storage. Storage tanks provide only 60 to 70 percent of the water at usable temperature due to stratification. House recirculation systems are not usually active enough to create 100 percent usable storage in a tank. Although Sellers heaters are equipped with internal baffles to provide a greater "draw down", the bottom of the tank may not be hot. An additional 30 to 40 percent usable hot water may prove to be very useful during peak loads.

BLENDING AND CONTROL

Forced circulation creates a blending effect which keeps the water from stratifying, thus a more uniform temperature is maintained throughout the tank. This is especially helpful when operating at higher temperatures. A build-up of high temperature hot water can form at the top of the heater as a result of a series of light draws on the hot water line. Excessive temperatures in an "upper" storage region can cause the unit to shutoff by the high limit safety or to open the temperature relief valve.

CONDENSATION PREVENTION

The external circulation system takes the water off the hot water outlet and forces it into the bottom of the tank. A continuous flow of hot water entering the coolest area of the tank keeps the tubes warm. During peak or high demand loads, this warmer temperature in the lower region of the tank helps prevent fireside condensation.

WHEN TO USE

- Continuous process loads; i.e., concrete operation
- When large storage capacities are required
- When high operating temperatures are needed
- When low recirculation flows exist in the system
- When application calls for "dump" loads of hot water

COMPONENTS FURNISHED

- Properly sized type L copper pipe and fittings
- Bronze or stainless steel circulating pump
- Pump isolation valves and check valve.
- Dielectric fittings on copper to steel connections
- Aquastat to control pump motor.

PUMPS PROVIDED REQUIRES A SEPARATE POWER SUPPLY

WATER SOURCE HEAT PUMP APPLICATION

A popular HVAC system uses a low temperature water source and a heat pump for building heat. Sellers can provide a factory packaged auxiliary low temperature heat source to take advantage of this highly efficient technology. This system eliminates the need for a standby boiler to supplement heavy draws on the heat pump.

ADVANTAGES

REDUCED INITIAL COST – REDUCED ENERGY COST - REDUCED MAINTENANCE COST - REDUCED FLOOR SPACE

The drawing to the right shows water source heat pump assembly and an external circulating system. The unit's primary function is to heat domestic water. When needed, the stored water is used as an auxiliary energy source for the heat pump. The heat exchanger keeps the heat pump loop up to temperature. The need for an additional boiler to heat the loop is eliminated. Each system is custom designed based on the following information:

Domestic heating requirement, GPH _____

Domestic water temperature _____ f. to _____ f.

Heat pump temperature _____ f. to _____ f.

Heat pump loop flow rate _____ f. to _____ f.

Heat pump load in BTU per hour _____

Water heater tank pressure(100,125,150 PSI)

